

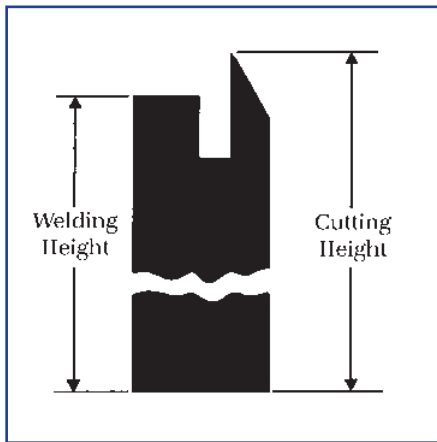

CUT-SEAL – COMBINED CUTTING AND WELDING ELECTRODE

These rules incorporate a cutting edge and a welding face in a single strip. The welding face may be plain or decorative, with or without a gap between the welding face and the cutting edge. Available on a 6 point body (2.10mm) and with a standard cutting height of 23.30mm (0.918"). Other heights can be readily supplied to order.

When ordering please specify cutting height and welding height required, also with or without bead. As a general guide the differential between the cutting and welding heights is normally half that of the combined thickness of material to be welded.



With bead

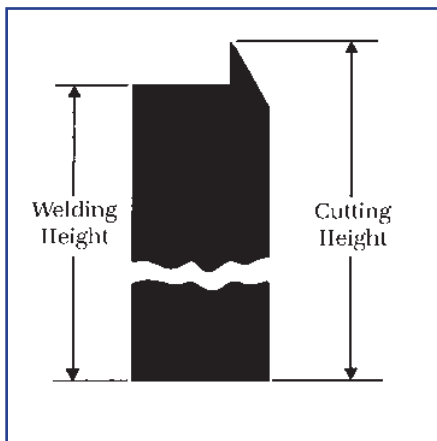

Without bead

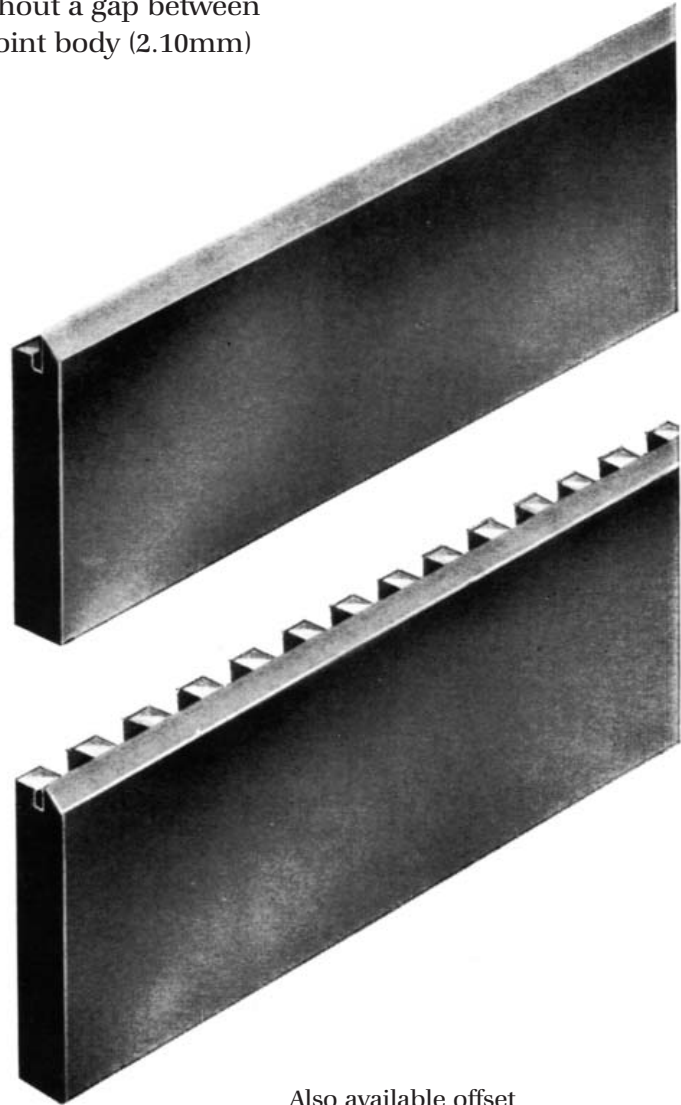

Also available offset

